

Certified according to DIN EN ISO 9001

Technical Datasheet



ZHM...KL Series

Gear Flow Meters with Ball Bearings
for lubricating and abrasive fluids.

Application

The gear flowmeters of the series "ZHM KL" are sensors of measured values for any lubrication and non-abrasive liquids, e.g. oils and greases. The parts of products of this series are manufactured exclusively of high-grade stainless steel, so the products of the series ZHM KL are exceptionally well suited for middle and high pressure of media.

Various design sizes of the flowmeters of the series ZHM KL allow a wide range of applications as consumption measuring, monitoring, mixing and dosing. Thanks to very precise ball bearings optimal measurement accuracy as well as good dynamic characteristics are guaranteed. Short reaction times and exact dosing and flow measuring can be therefore performed in different areas of applications.

Applications

- Filling systems
- Dosing systems
- Monitoring of lubricated points

Features

- Stainless materials
- Short reaction times
- High accuracy of dosing

Principle and Design

Gear flowmeters are volumetric counters that have internal design similar to gear pumps. There are two gear wheels inside the flowmeter body; they have mutual engagement with a minimum backlash.

Between the teeth and walls of the flowmeter body closed chambers arise into which medium forced-flows and it puts thereby the gear wheels in motion.

The gear wheels move freely and do not brake the medium flow. Their number of revolutions is proportional to the medium flow rate and is sensed using contactless sensors through the body wall.

Technical Data

Type	Measuring range, l/min		K-Factor, pulses/l ⁽¹⁾	max. Pressure, bar	Frequency, in Hz ⁽¹⁾		Weight, kg
ZHM 01/3 KL*	0.002	to 0.5	40,000	315	1.3	to 330	2.2
ZHM 01/2 KL*	0.02	to 3	14,000	630	4.6	to 700	1.3
ZHM 02 KL*	0.1	to 7	4,200	630	7	to 490	2.2
ZHM 03 KL*	0.5	to 25	1,740	630	14	to 730	2.9
ZHM 04 KL*	0.5	to 70	475	630	4	to 560	8.5
ZHM 05 KL*	5	to 150	134	400	11	to 340	23
ZHM 06/1 KL*	5	to 250	106	400	8.8	to 450	27
ZHM 06 KR*	10	to 500	53	400	18	to 450	35
ZHM 07 KR*	50	to 1,000	24	400	20	to 400	66.5

1) Average values with single-pickup TYP VTE*/P. Use twin-pickup for higher resolution.

* Detailed type code on request

General	
Linearity	± 1% of actual flow (≥ 30 mm ² /s; up to 0.1% with linearization electronics)
Repeatability	± 0.1%
Materials	Housing: as per DIN 1.4305 (SS303), 1.4404 (SS316L) Gears: as per DIN 1.4122 (SS303), 1.4501 (UNS 32760) Bearing: Ball bearing: carbide (ZHM 01/2-04) / Chrome steel (ZHM 05) Tapered roller bearings: chrome steel (ZHM 06-07) Sealing: FKM, PTFE
Medium temperature	-20 to +180°C (higher temperatures on request)
Dimensions	See drawing (page 4 to 5)

Pickup Selection

Criteria	Type	VTE *	WT */ WI*	VIE *	IF */ VIEG	VTC *	VTB *	TD *	VHE*	FOP *
		Drilling type ¹⁾	E	E	E	E	E	E	D	E
Medium temperature	≤ +70°C							X		
	≤ +120°C					X	X		X	X
	≤ +150°C	X	X	X						
	≤ +350°C				X					
EX-Approval	X	X	X	X	X	X	X	X		X
Frequency output	X	X	X	X	X		X	X	X	X
Dual frequency output								X		
Analogue output 4 - 20 mA		X				X				
Forward / backward recognition								X		
Display Vorort						X	X			
Linearization			X			X				
Supply 12 - 24 V	X	X	X	X	X	X		X	X	
Supply battery							X			X
Interface			X			X				

1) Drilling types: E: single pickup / D: dual pickup / F: FOP-pickup

* Ordering code (please see separate datasheet)

Dimensional Drawings (mm) - ZHM 01/2 to 05

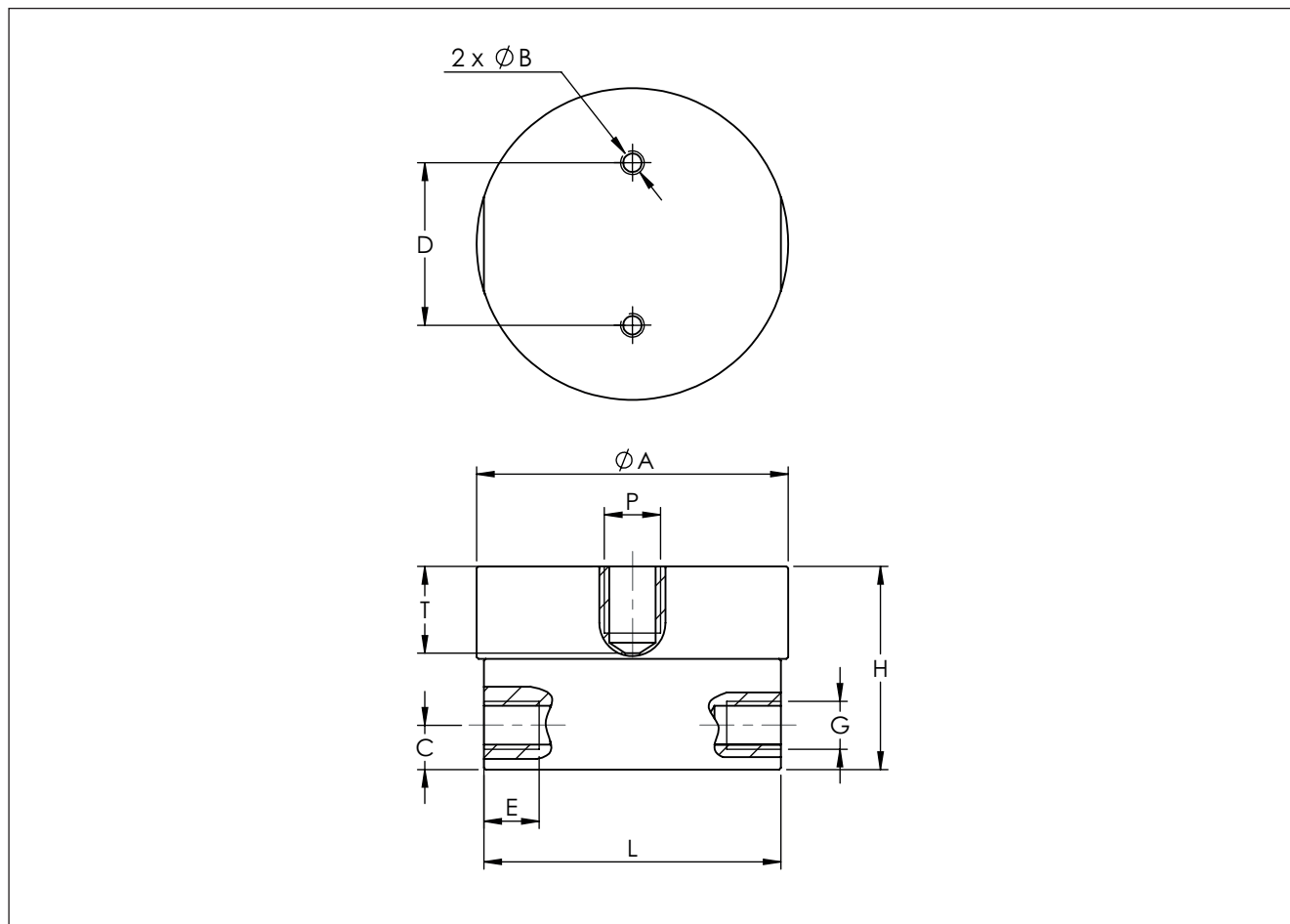

ZHM Type	$\varnothing A$	B	C	D	E	G	H	L	P ¹⁾	T ²⁾
ZHM 01/2 KL	76	M6 ∇ 10	12	44	14	G1/4" M12x1.5 1/4"NPT G1/8"	50	72	E/D/F	18
ZHM 01/3 KL	84.4	M6 ∇ 10	12	44	14	G1/4" G1/8" 1/4"NPT	55	80,5	E/D/F	24.4
ZHM 02 KL	84.4	M6 ∇ 10	12	44	14	G1/4" 1/4"NPT	55	80,5	E/D/F	23.5
ZHM 03 KL	84.4	M6 ∇ 10	12	44	14	G1/4" M12x1.5 G3/8" 1/4"NPT	67	80,5	E/D/F	23.5
ZHM 04 KL	125	M6 ∇ 10	17	60	14	1/2"NPT M20x1.5 G1/2"	96	121	E/D/F	30.5
ZHM 05 KL	175.5	M8 ∇ 15	22.5	100	18	M33x2 G1"	133	170	E/D/F	43.5

1) See "Pickup Selection" table (P. 3)

2) Please notice: total height is calculated by adding up the height (H) and the height of the pickup (separate data sheet) and subtract the bore hole depth (T)

Dimensional Drawings (mm) - ZHM 06/1 to 07

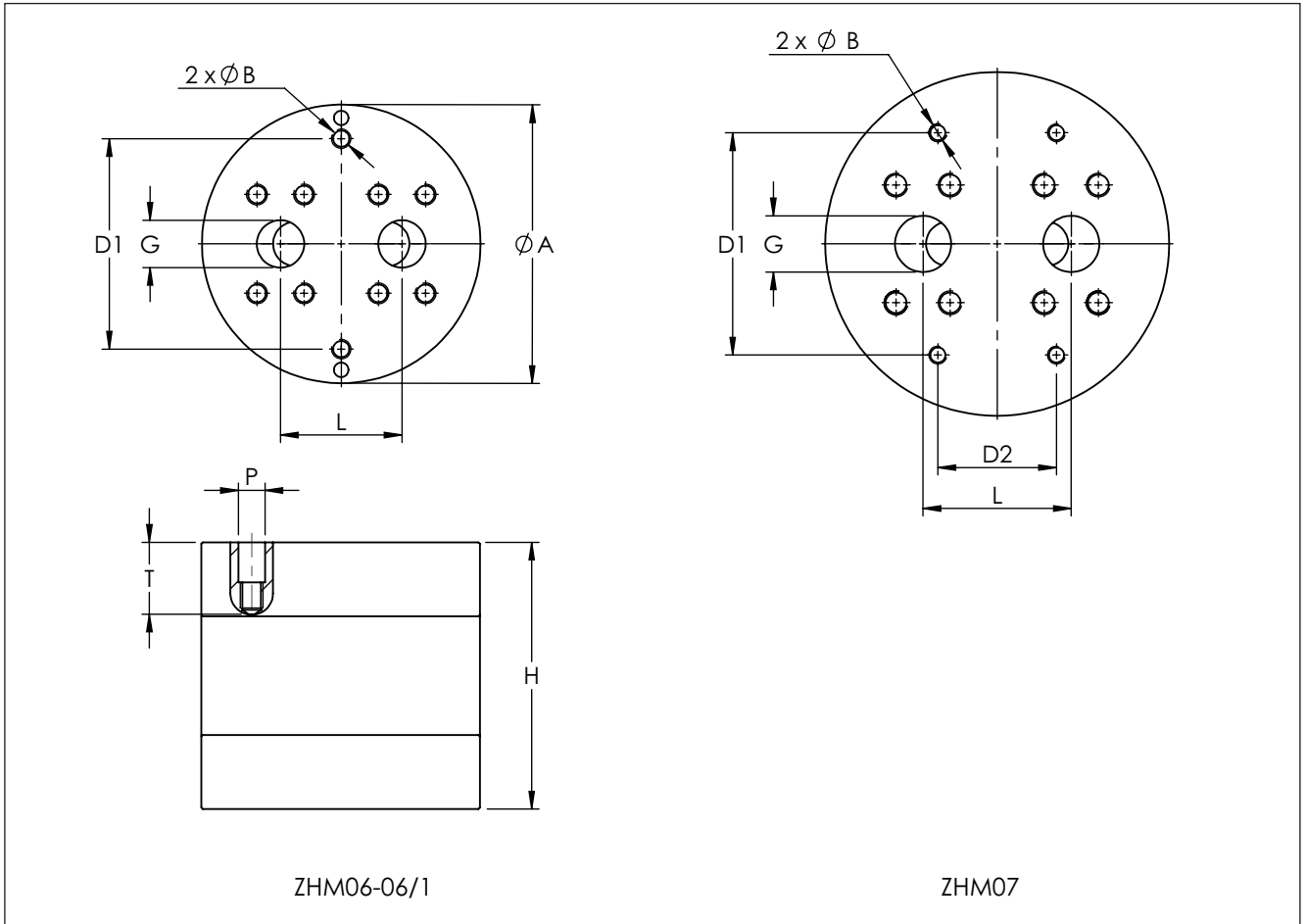

ZHM Type	Ø A	B	D1	D2	G	H	L	P ¹⁾	T ²⁾
ZHM 06/1 KL	188.5	M12 ↓ 25	142	-	SAE 1 1/4"	138	82	B/E/D/S	48.5
ZHM 06 KR	188.5	M12 ↓ 25	142	-	SAE 1 1/4" SAE 1 1/2"	180	82	E/D/H/S	48.5
ZHM 07 KR	233	M12 ↓ 25	150	80	SAE 1 1/2"	220	100	E/S/H	63.5

1) See "Pickup Selection" table (P. 3)

2) Please notice: total height is calculated by adding up the height (H) and the height of the pickup (separate data sheet) and subtract the bore hole depth (T)

KEM Headquarter

Liebigstraße 5
85757 Karlsfeld
Germany

T. +49 8131 59391-0
F. +49 8131 92604

info@kem-kueppers.com

KEM Service & Repairs

Wetzeller Straße 22
93444 Bad Kötzing
Germany

T. +49 9941 9423-0
F. +49 9941 9423-23

info@kem-kueppers.com

*More distributors & partners can be found at:
www.kem-kueppers.com*

Your local partner:



www.kem-kueppers.com
info@kem-kueppers.com