

MX19 – 3/4” DIGITAL FLOW METERS

SUITABLE FOR FLOW RANGE 3-80L/MIN



MX19P-1SE
Stainless steel body with LCD register

Output variations:



- B - Ex approved (Ex ia)**
Intrinsically Safe - NPN
- N - Ex approved (Ex ia)**
Intrinsically Safe - NAMUR
- T - High Temperature**
Max temp- 150°C



- F - ER**
LCD Display (17mm)
- G- ERA**
LCD Display (17mm)
- H- ERB**
LCD Display (17mm)
Batch controller



- D - PR**
LCD Display (12mm)
- E - PRA**
LCD Display (12mm)
with outputs



- A - Standard Pulse**
Reel/Hall Effect
- I - Standard Pulse**
Reel/Reed Effect
- J - Standard Pulse**
Hall/Hall Effect
- K - High Resolution**
Hall NPN

The MX19 3/4” Digital Flow Meters are suitable for flows between 3-80L/min. The 3/4” Digital Flow Meters have an accuracy of +/- 0.5% and provides exceptional levels of reliability and durability.

SPECIFICATIONS

	MX19F	MX19S	MX19P
Materials of Construction Meter Body	Aluminium (6061)	Aluminium (6061)	Stainless Steel (316)
Rotor	PPS	Stainless Steel (316)	PPS Stainless Steel (316)
Seals	Fluorocarbon (FKM)	PTFE encapsulated (FEP)	PTFE encapsulated (FEP)
Design Specifications Process Connections	Threaded 3/4" G 3/4" NPT	Threaded 3/4" G 3/4" NPT	Threaded 3/4" G 3/4" NPT
Technical Specifications Flow rate	<5cP 8-70L/min 2-18.5USG/min	<5cP 8-70L/min 2-18.5USG/min	<5cP 8-70L/min 2-18.5USG/min
Operating Temperature Range*	>5cP 3-80L/min 0.8-21USG/min	>5cP 3-80L/min 0.8-21USG/min	>5cP 3-80L/min 0.8-21USG/min
Max. Operating Pressure	-40 - 80°C -40 - 176°F	-40 - 120°C -40 - 248°F	-40 - 80°C (150°C with high temp. rotors) -40 - 176°F (302°F with high temp. rotors)
Accuracy	2000 psi 138 Bar	2000 psi 138 Bar	2000 psi 138 Bar
Repeatability	+/- 0.5%	+/- 0.5%	+/- 0.5%
Nominal K-Factor	+/- 0.03%	+/- 0.03%	+/- 0.03%
	52 Pulses/L	52 Pulses/L	52 Pulses/L

*Temperature based on standard pulse output - subject to change dependant on rotor and output type, contact Macnaught technical support for further investigations

OUTPUTS TYPES

	DESCRIPTION	SWITCH TYPE	OUTPUT TYPE	MX19F	MX19S	MX19P
X	No Output	-	No Output	●	●	●
A	Standard Pulse	Reed /Hall (NPN)	Pulse (1m flying lead)	●	●	●
B	Ex approved (Ex ia)	Hall (NPN)	Pulse (2m DIN cable)	—	●	●
D	PR (LCD 12mm display)	-	Display 12mm	●	●	●
E	PRA (LCD 12mm display)	-	Display 12mm, 4-20mA output, Pulse	●	●	●
F	ER (LCD 17mm display)	-	Display 17mm	●	●	●
G	ERA (LCD 17mm display)	-	Display 17mm, 4-20mA output, Pulse	●	●	●
H	ERB (LCD 17mm display)	-	Display 17mm + Batch Control	●	●	●
N	Ex Approved (Ex ia NAMUR)	NAMUR	Pulse (2m DIN cable)	—	●	●
T	High Temperature	Hall (NPN)	Pulse	✗	S	S
I	Reed/Reed	Reed/Reed	Pulse (1m flying lead)	—	—	—
J	Hall/Hall	Hall/Hall	Pulse (1m flying lead)	—	—	—
K	High Resolution (omnipolar)	Hall (NPN)	Pulse (1m flying lead)	—	—	—

● Available ✗ Not Available S Only with stainless steel rotors — Consult Macnaught Technical regarding availability

DIMENSIONS

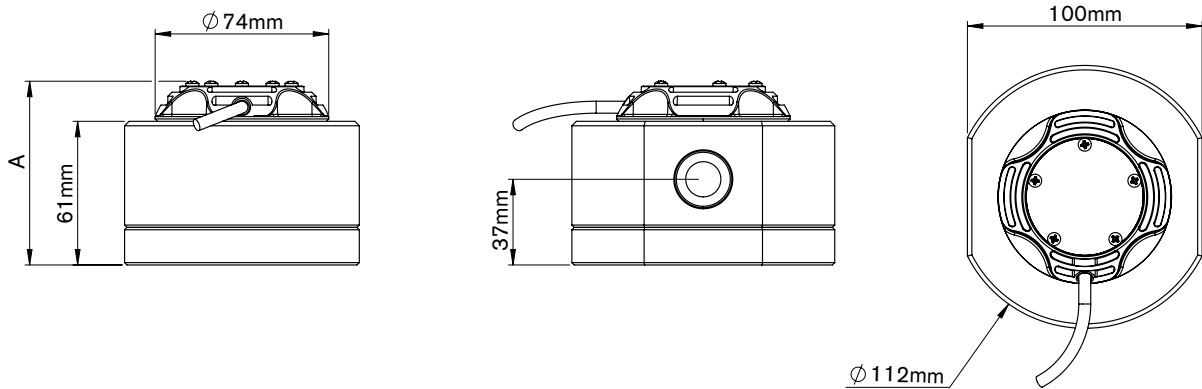

PULSER AND DISPLAY HEIGHT - A

