

Technical Datasheet



HM R Series

Turbine Flow Meters
with BSP Threads

Description

The HM R turbine flow meter series (R for Female Inch Threads) is used to measure continuous and discontinuous flow rates. They are mainly used for lubrication and non-lubrication media. They are particularly suitable for low and medium viscosity liquids, such as water, emulsions, glycol mixtures and light oils. Even the measurement of cryogenic fluids is possible.

Only high-grade steels that can withstand corrosive liquids are used in the production of turbine flow meters. Combined with the use of tungsten carbide bearings, the HM R guarantees optimum measurement accuracy and an extremely long service life even under the toughest application conditions.

The combination of various turbine wheel dimensions and blade geometries allows a wide range of sizes that can cover a huge measuring range. This makes the HM R ideal for a variety of applications in the field of metering as well as for monitoring, mixing and dosing.

Short response times, very dynamic performance and high measurement accuracy ensure accurate regulation and control of flow rates in the most demanding applications.

For applications in hazardous areas, we offer intrinsically safe sensors and amplifiers with Ex protection in accordance with ATEX, IECEx, CSA and other standards. Additional certifications such as EAC (TR-CU) are available.

Principle and Design

Turbine flow meters (HM) are volume counters operating on the Woltmann impeller counter principle. They use the average flow velocity to record the flow rate through the pipe.

The flow of the medium is directed at the turbine wheel in the axial direction and so rotated. The speed of the freely turning wheel over a wide range is directly proportional to the average flow velocity. The low weight of the turbine wheel ensures very short response times as well as very dynamic behaviour in flow changes. Two flow straighteners generate quasi-laminar flow, which in turn contributes to increasing the measurement accuracy.

The speed of the turbine wheel is measured by the sensor through the housing wall. The sensor system can be selected to meet the requirements of the individual application. This can provide, for example, a signal to indicate the direction of flow.

Pulses per unit of volume are available for analysis. The calibration factor (K-factor) of the flow meter describes the exact pulse rate per unit of volume. In order to determine the individual calibration factor of a flow meter, we calibrate each of our meters in house prior to delivery. The operating viscosity specified by the customer is taken into account for calibration. A corresponding calibration certificate is included with every flow meter we supply.

The KEM turbines feature a short response time between 5 and 50 ms depending on the nominal diameter, which is advantageous for precise filling processes.

Turbine flow meters have a resolution of up to 3,000 pulses per litre. The milled and turned precision components are the reason why the HM series has neither wetted weld seams nor soldered connections. All market-related requirements for piping and material standards can thus be fully guaranteed.

Applications

- Consumption measurement
- Filling process
- Dosing systems
- 2-component mixing plants
- Test stands
- Water (normal and demineralized)
- Hydraulic and gear oils
- Fuels, gasoline, kerosene
- Coolants
- Additives
- Solvents
- Pharmaceutical liquids
- Cryogenic fluids

Features

- High measuring accuracy up to $\pm 0.1\%$ ¹⁾
- Exceptional repeatability of $\pm 0.05\%$
- Short response times (from 5 ms)
- Robust carbide bearing
- Medium temperature: -60 °C up to $+350\text{ °C}$ [-76 °F up to $+662\text{ °F}$]
- Different nominal sizes
- Pressure stage up to 630 bar [9,140 psi]

¹⁾ Under laboratory conditions; incl. linearization; viscosity $\geq 1\text{ mm}^2/\text{s}$.

Technical Data – Sizes

HM Type ²⁾	Measuring Range ³⁾ (l/min)			K-Factor ⁴⁾ (pulses/l)		max. Pressure (bar/psi)	max. Frequency ⁴⁾ (Hz)		Weight (kg)
				≥ 1 cst	> 8 cst		≥ 1 cst	> 8 cst	
HM 003 R	0.3	to	1.5	32,000	32,500	630 [9,140]	1,100	—	0.3
HM 004 R	0.5	to	4	24,000	19,500	630 [9,140]	1,170	—	0.3
HM 005 R	0.8	to	6	17,800	17,800	630 [9,140]	1,740	—	0.4
HM 006 R	1.2	to	10	11,000	11,000	630 [9,140]	2,100	—	0.4
HM 007 R	2.0	to	20	5,200	5,200	630 [9,140]	1,800	—	0.5
HM 009 R	3.3	to	33	1,900	4,200	630 [9,140]	1,080	2,200	0.5
HM 011 R	6.0	to	60	1,300	2,730	400 [5,800]	1,350	2,700	0.5
HM 013 R	8.5	to	85	900	1,900	400 [5,800]	1,300	2,600	0.9
HM 019 R	15	to	150	310	650	400 [5,800]	925	2,000	1.3
HM 028 R	30	to	360	155	320	315 [4,570]	960	2,000	2.6
HM 030 R	35	to	400	130	270	315 [4,570]	1,000	1,800	2.9

Technical Data – General

Measuring Accuracy	±0.1 % ⁵⁾
Repeatability	±0.05 % (under the same conditions)
Linearity	±1 % of actual flow
Measuring Span	Standard: 1:10 Extended: on request
Viscosity Range	0.8 up to 30 mm ² /s
Materials	Housing: as per DIN 1.4404 [AISI 316L], others on request Wheels: as per DIN 1.4460 [AISI 329], others on request Bearing: Tungsten carbide sleeve bearing
Medium Temperature	-60 °C up to +350 °C [-76 °F up to +662 °F]
Dimensions	See dimensional drawing (page 4)



²⁾ Exact type designation on request.

³⁾ Extended measuring ranges on request.

⁴⁾ Average values for single sensors at viscosity of 1 mm²/s; higher viscosities may differ.

⁵⁾ Under laboratory conditions; incl. linearization; viscosity ≥1 mm²/s.

Turbine Flow Meters – HM R Series

Dimensional Drawing

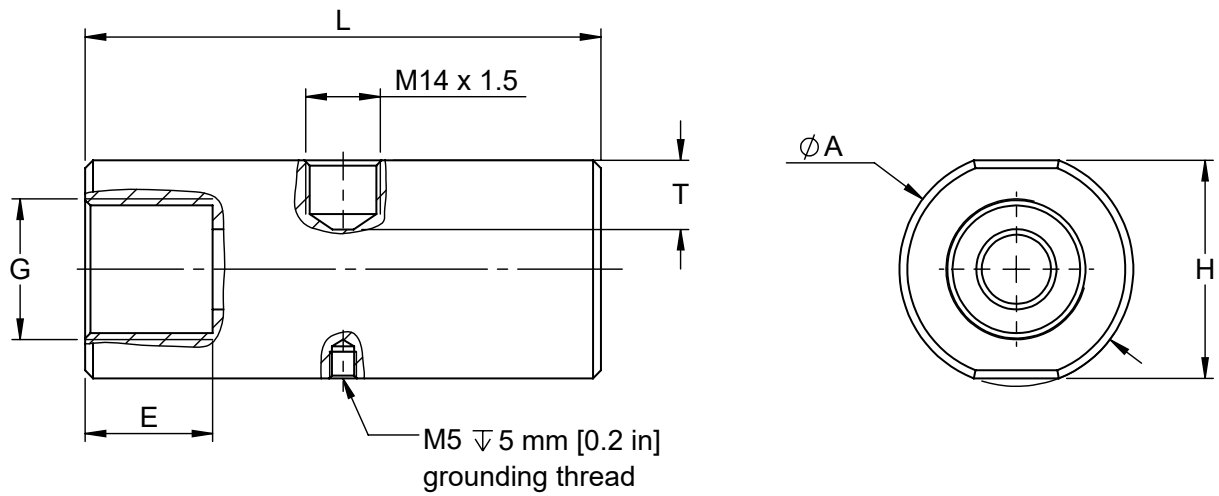

HM Type	A	E	G	H	L	T
HM 003 R	34 mm [1.34 in]	12.5 mm [0.49 in]	G ¼"	30 mm [1.18 in]	60 mm [2.36 in]	12 mm [0.47 in]
HM 004 R	34 mm [1.34 in]	12.5 mm [0.49 in]	G ¼"	30 mm [1.18 in]	60 mm [2.36 in]	12 mm [0.47 in]
HM 005 R	34 mm [1.34 in]	12.5 mm [0.49 in]	G ⅜"	30 mm [1.18 in]	70 mm [2.76 in]	11 mm [0.43 in]
HM 006 R	34 mm [1.34 in]	12.5 mm [0.49 in]	G ⅜"	30 mm [1.18 in]	70 mm [2.76 in]	11 mm [0.43 in]
HM 007 R	34 mm [1.34 in]	12.5 mm [0.49 in]	G ⅜"	30 mm [1.18 in]	74 mm [2.91 in]	10 mm [0.39 in]
HM 009 R	34 mm [1.34 in]	12.5 mm [0.49 in]	G ⅜"	30 mm [1.18 in]	79 mm [3.11 in]	9 mm [0.35 in]
HM 011 R	34 mm [1.34 in]	12.5 mm [0.49 in]	G ⅜"	30 mm [1.18 in]	86 mm [3.39 in]	8 mm [0.31 in]
HM 013 R	44 mm [1.73 in]	16.5 mm [0.65 in]	G ¼"	41 mm [1.61 in]	97 mm [3.82 in]	13 mm [0.51 in]
HM 019 R	49 mm [1.93 in]	18.5 mm [0.73 in]	G 1"	46 mm [1.81 in]	125 mm [4.92 in]	12 mm [0.47 in]
HM 028 R	64 mm [2.52 in]	22.5 mm [0.89 in]	G 1½"	60 mm [2.36 in]	161 mm [6.34 in]	15 mm [0.59 in]
HM 030 R	64 mm [2.52 in]	22.5 mm [0.89 in]	G 1½"	60 mm [2.36 in]	181 mm [7.13 in]	14 mm [0.55 in]

Calibration

In-house calibration is performed on volumetric calibration rigs or in our DAkkS calibration laboratory, depending on the needs of the client.

The KEM calibration lab uses a high-precision load cell system. With an accuracy of 0.05 % for the mass and 0.1 % for the volume of flowing liquids, we occupy a leading position worldwide. The German Accreditation Body (DAkkS) has accredited the laboratory engineers, processes and measuring equipment in accordance with the international standard DIN EN ISO/IEC 17025:2018.

The KEM calibration certificate not only verifies the accuracy of a flow meter, but also guarantees its traceability to national standards ensuring all requirements according to international quality standards are met.

The calibrations are performed with different hydrocarbons. This ensures the optimum simulation of changing operating conditions in density and viscosity even when temperatures change. This way the primary viscosity for the use of the flow meter can be specifically taken into account when viscosity fluctuations occur in a customised application.

The calibration result is the specified calibration factor (K-factor) in pulses per litre. This K-factor accordingly applies only at a certain flow velocity or a certain flow rate.

The calibration factor varies only very slightly at different volume flow rates. The individual measuring points provide the calibration curve of the flow meter from which the average K-factor is determined. The average calibration factor applies to the entire measuring range.

The linearity specification (percent deviation) refers to the average K-factor. To further increase the measurement accuracy in onsite use, the specific K-factors can be used to calculate the flow rate. For this, KEM also supplies optional special electronics.

Calculation of volume flow

The flow is directly dependent on the measured frequency and the associated calibration factor:

$$Q = \frac{f \cdot 60}{K} \text{ l/min}$$

- Q = Volume Flow
- f = Measuring frequency
- K = Specific K-Factor

Calibration protocol

Example: HM R 050

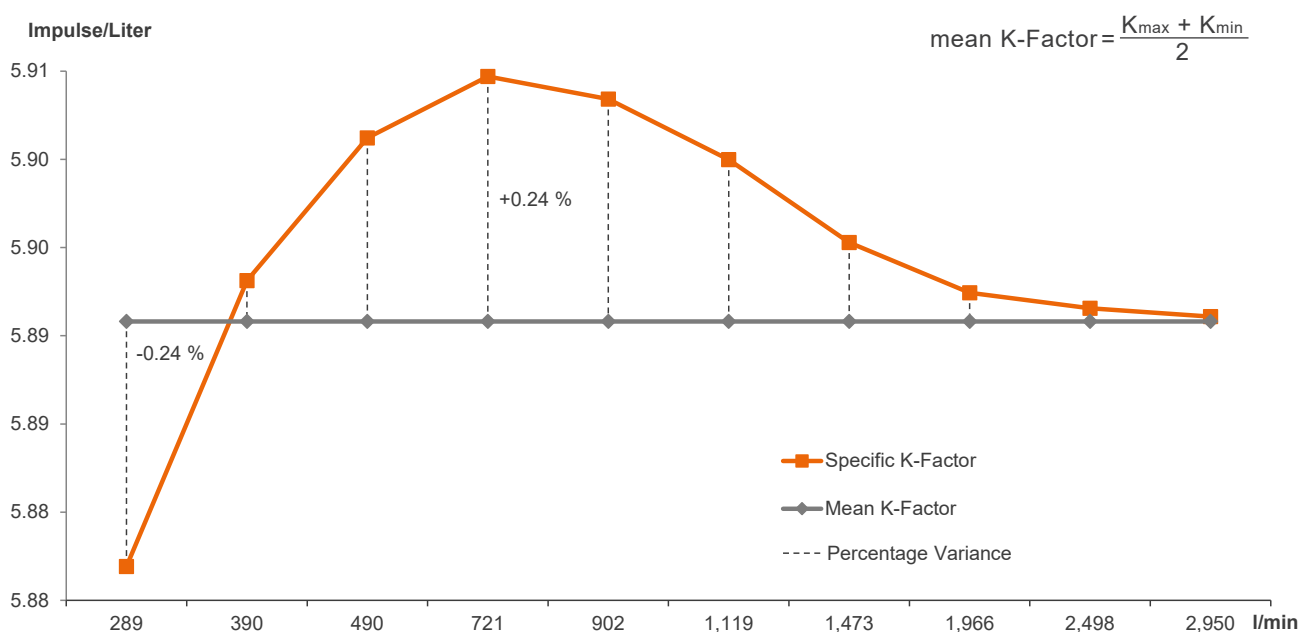



KEM Headquarters

Liebigstraße 5
85757 Karlsfeld
Germany

T. +49 8131 59391-0
F. +49 8131 92604
info@kem-kueppers.com

KEM Manufacturing Center

Wetzeller Straße 22
93444 Bad Kötzing
Germany

T. +49 9941 9423-0
F. +49 9941 9423-23
production@kem-kueppers.com

KEM Sales

Liebigstraße 5
85757 Karlsfeld
Germany

T. +49 8131 59391-100
F. +49 8131 92604
sales@kem-kueppers.com

KEM Service & Repairs

Wetzeller Straße 22
93444 Bad Kötzing
Germany

T. +49 9941 9423-37
F. +49 9941 9423-24
service@kem-kueppers.com

*More distributors & partners can be found at:
www.kem-kueppers.com*