

Coriolis Mass Flow Sensor
Mass-flow Sensor for standard applications



TMU
2nd Generation



- Extreme compact lightweight design
- Measuring ranges from 60 kg/h to 2,200 t/h
- Immune to external vibrations
- Immune to pipeline induced stresses
- Variety of tube materials available
- Extensive selection of process connections
- Optional sensor heating



Function

The TMU Coriolis flow Sensors utilizes the Coriolis principle for the direct measurement of mass flow.

The sensor possesses two parallel-arranged tubes, which are continuously force-vibrated at their resonance frequency. When a fluid or gas passes through the tubes, the mass flow momentum in conjunction with the Coriolis effect invokes a change in the tubes deflection, causing the inlet and outlet legs of the tubes to twist out of phase.

Coupled with a UMC transmitter, the phase shift is captured and evaluated, the derived linear output being proportional to the mass-flow.

Technical Details

Sensor System:	TMU
System:	Coriolis dual-bent tubes TMU-x004 to TMU-x300 (<i>x denotes tube material</i>)
Accuracy liquid: Up to TMU050:	0.1 % of actual flowrate ± ZP stability
TMU080 and larger:	0.15 % of actual flowrate ± ZP stability
Accuracy gas: All Sensors	0.5 % of actual flowrate ± ZP stability
Wetted Parts: (<i>Standard</i>)	316 TI/1.4571, 316 L/1.4404 Hastelloy C-22 Tantalum <i>others on request</i>
Process Connections:	All standard flanges on stock. Special on request
Sensor containment:	1.4301 Stainless Steel
Ex-Classification:	II 1/2G Ex ia IIC T2...T6 Ga/Gb
Ambient temperature:	-40 °C ... +80 °C (-40 °F ... +176 °F)
Process temperature:	-50 °C ... +220 °C/260 °C * (-58 °F ... +428 °F/500 °F) * * (<i>260 °C / 500 °F for max. 1 hour</i>)
Process Pressures:	Dependant on sensor size
Ingress Protection:	IP67 (EN 60529) / NEMA 6

Application

The TMU Coriolis Mass Flow Sensors are designed for measuring the mass-flow, density and volume flow of almost all liquid and gaseous media.

Available as a standard configuration with a variety of process connections, the TMU sensors are optimised for the use in innumerable applications common to chemical, petrochemical, oil and gas, food and pharmaceutical industries.

The TMU Series also has a proven track record for use in precise dosing systems as well as in loading and unloading applications.

Available Transmitters:

UMC3

Ex-Classification: II (1)2G Ex d [ia Ga] IIB/IIC T6 ...T3 Gb
II (1)2G Ex d e [ia Ga] IIB/IIC T6 ...T3 Gb
- BE2 Control unit: II 2G Ex ia IIC T6 Gb

UMC4

Ex-Classification: II 2G Ex d [ia Ga] IIC T3 ... T4 Gb

UMC4-RM

Ex-Classification: II 3G Ex ec [ia Ga] IIC T3 ...T6 Gc

For a detailed description of the transmitter specifications, refer to the respective transmitter datasheet

Sensor Approvals:

Hazardous locations: ATEX / IECEx / cCSA_{US} /
KTL (Korea) / NEPSI (China)
Marine approved: DNV / ABS
Custody Transfer: OIML R117 Type Approval

Order Details Sensor (Example TMU-S040-321B-A00-GL-11-Z-H)

Model	Wetted Materials	Measuring range	Process connections	Containment Options	Heating / Cooling
TMU-	S = Stainless Steel 1.4404 (316 L) 1.4571 (316 TI) H = Hastelloy C-22 T = Tantalum ¹⁾ X = Customer specified	008 = 600kg/h to 300 = 2200t/h ²⁾	-321B = DN50 PN40 ³⁾ Form B1 DIN EN 1091-1	-A = Stainless steel containment -X = Customer specified	0 = none A = with heating X = Customer specified

¹⁾ Tantalum sensor only available up to size TMU-T080

²⁾ Refer to flow range table on page 4

³⁾ contact Heinrichs sales department for a full list of connections

Connection for Heating/Cooling	Sensor Configuration/ Process Temperature	Approvals	Calibration Flow	Calibration Density ¹⁾	Supp. Equipment	Design
0 = none X = ²⁾	-G = remote Mount -50 °C ... +180 °C M20 x1.5 mm entry with terminal blocks	B = NEPSI K = KCS L = ATEX/IECEX S = Marine	-1 = 3-point -2 = 10-point -3 = external lab. -7 = 7-point OIML -X = Customer specified	0 = none 1 = 3 point 2 = 5 point X = Customer specified	-0 = none -Z = with -X = Customer specified	-H = Heinrichs -K = Kobold

¹⁾ Not available for gas meters

²⁾ Contact Heinrichs sales department for a full list of connections

Standard Flow Ranges

Model	Max. measuring range	Nominal ($\Delta p=1\text{bar}$)	Zero point stability (of range)
	kg/h [lbs/min]	kg/h [lbs/min]	kg/h [lbs/min]
TMU-x008	600 [22,0]	330 [12,1]	0,03 [0,001]
TMU-x010	2500 [91,9]	1150 [42,3]	0,125 [0,005]
TMU-x012	8000 [293,9]	3650 [134,1]	0,4 [0,015]
TMU-x015	12000 [440,9]	5250 [192,9]	0,6 [0,022]
TMU-x020	25000 [918,6]	14250 [523,6]	1,25 [0,046]
TMU-x025	30000 [1102,3]	20000 [734,9]	1,5 [0,055]
TMU-x040	60000 [2204,6]	55000 [2020,9]	3 [0,110]
TMU-x050	80000 [2939,4]	74000 [2719,0]	4 [0,147]
TMU-x080	120000 [4409,2]	118000 [4335,7]	12 [0,4]
TMU-x100	200000 [7348,6]	200000 [7348,6]	20 [0,7]
TMU-x150	460000 [16901,8]	460000 [16901,8]	46 [1,7]
TMU-x200	700000 [25720,2]	700000 [25720,2]	70 [2,6]
TMU-x250	1500000 [55114,6]	1350000 [49603,2]	150 [5,5]
TMU-x300	2200000 [80834,8]	1900000 [69811,9]	220 [8,1]

* ($\Delta p=0,87\text{bar}$)

** ($\Delta p=0,95\text{bar}$)

*** ($\Delta p=0,93\text{bar}$)

**** ($\Delta p=0,66\text{bar}$)

Pressure Ratings

All Sensor sizes are available with standard flanges according to Class 150 and PN40 / Class 300 pressure ratings.

Depending on the sensor size, higher-pressure rated flanges are available upon request.

Contact our sales department for more information.

Dimensions

Dimensions for Sensor up to TMU-x050

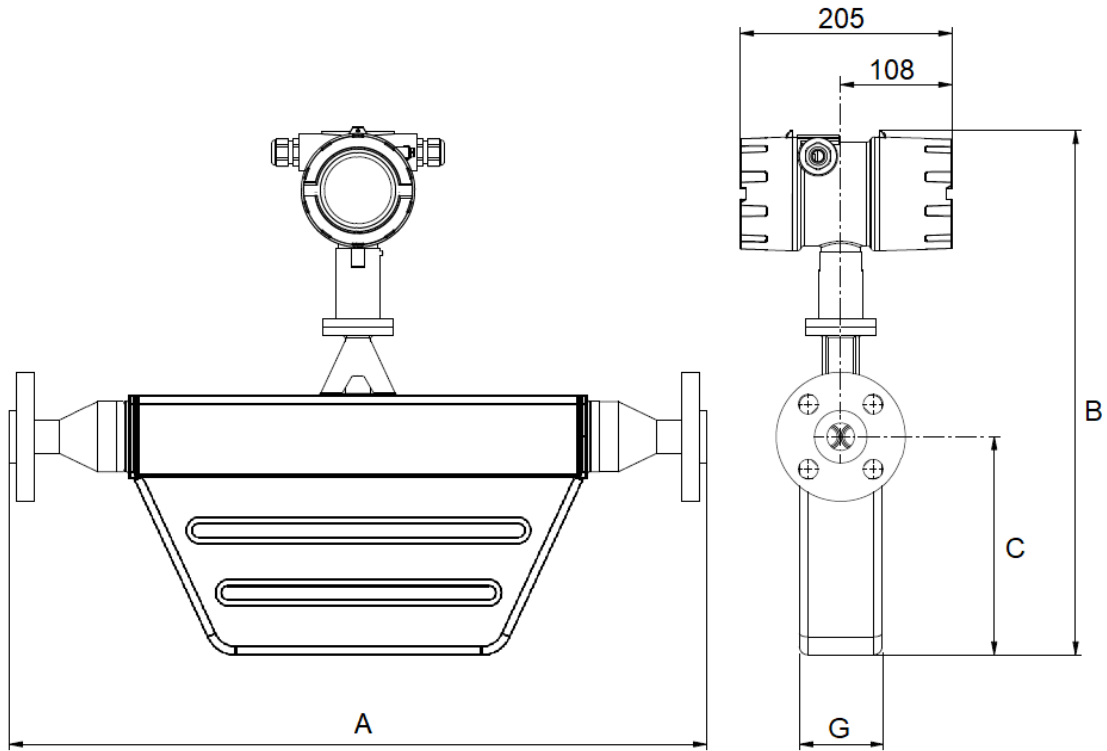

Dimensions on page 7

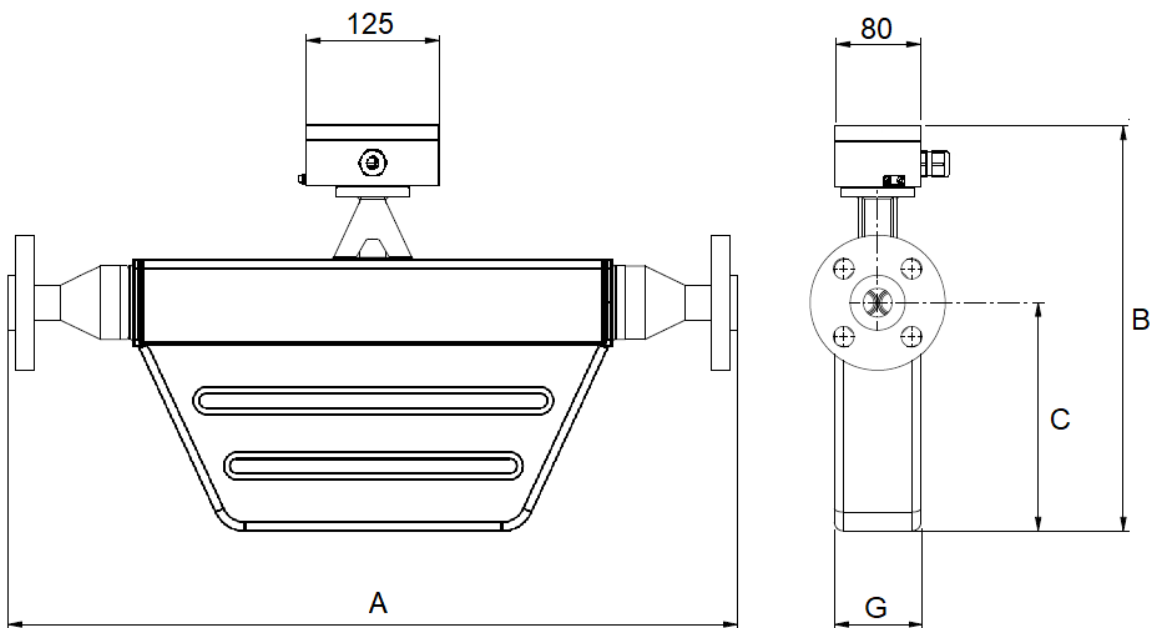

Dimensions on page 7

Dimensions for TMU Sensors TMU-x080 to TMU-x300

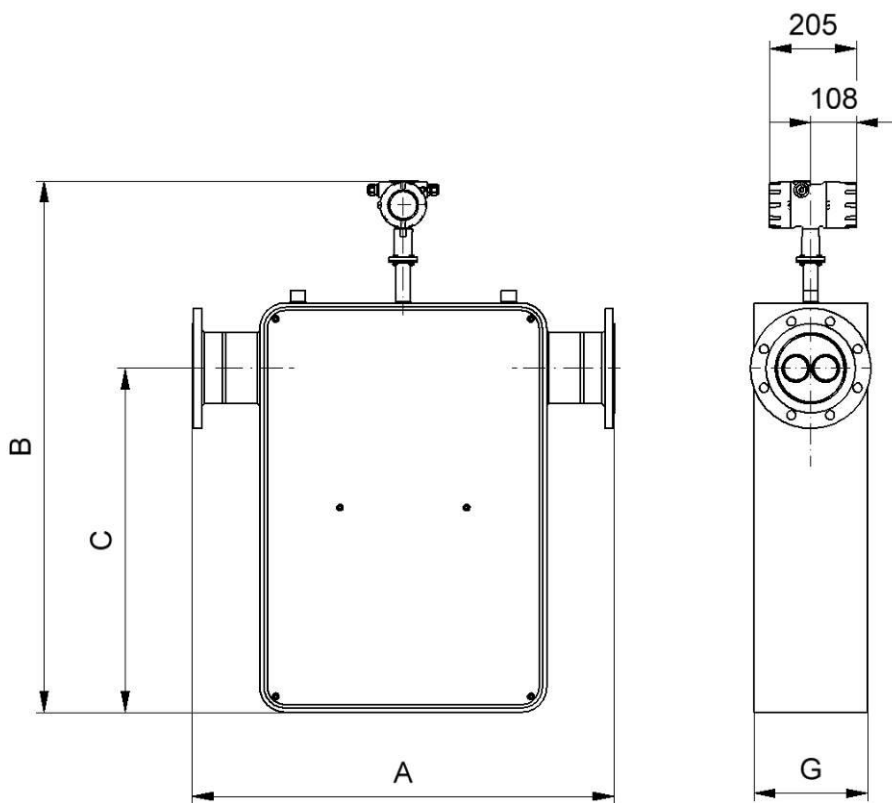

Dimensions on page 7

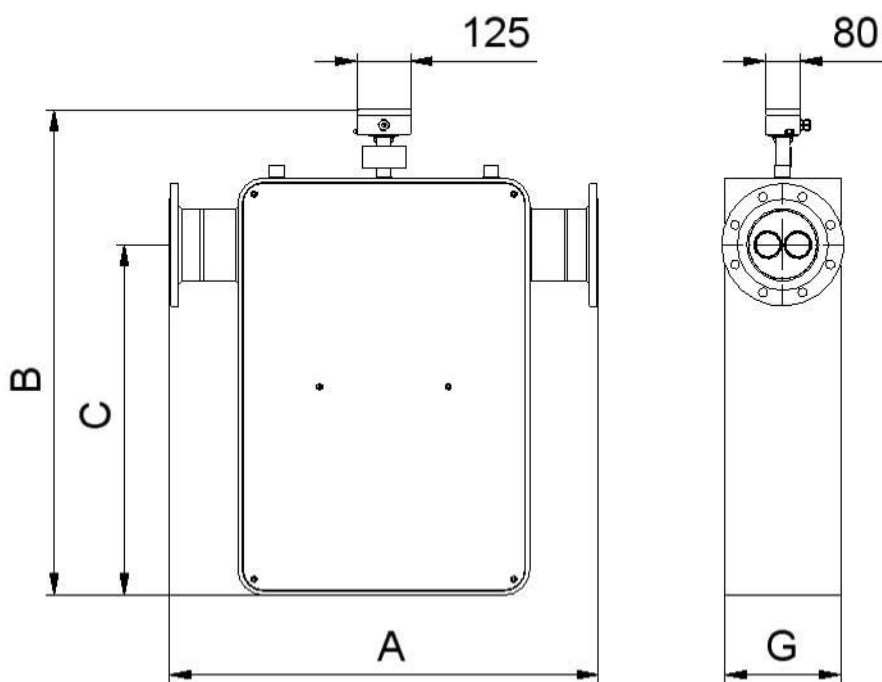

Dimensions on page 7

Table of installation lengths

A												
Model	Process connection	mm [inch]	Process connection	mm [inch]	Process connection	mm [inch]	Process connection	mm [inch]	Process connection	mm [inch]	Process connection	mm [inch]
TMU-x008	SW10	--	SW12	--	DN10	300 [11,8]	½" NPT (f)	320 [12,6]	½" NPT (f)	320 [12,6]	½" 150lb ½" 600lb	300 [11,8] 330 [13,0]
TMU-x010	SW12	--	DN10	390 [15,4]	DN15 DN25	410 [16,1] 410 [16,1]	½" NPT (f)	380 [15,0]	½" 150lb ½" 600lb	380 [15,0] 390 [15,4]	¾" 150lb ¾" 600lb	380 [15,0] 390 [15,4]
TMU-x012	-	--	DN15	490 [19,3]	DN25	500 [19,7]	½" NPT (f)	460 [18,1]	¾" 150lb ¾" 300lb	480 [18,9] 490 [19,3]	1" 150lb 1" 300lb	490 [19,3] 500 [19,7]
TMU-x015	-	--	DN15	500 [19,7]	DN25	500 [19,7]	½" NPT (f)	460 [18,1]	½" 150lb ½" 600lb	460 [18,1] 460 [18,1]	¾" 150lb ¾" 600lb	480 [18,9] 500 [19,7]
TMU-x020	-	--	DN25	--	DN40 DN50	-- --	¾" 150lb ¾" 600lb	-- --	1" 150lb 1" 600lb	-- 675 [26,6]	1½" 150lb 1½" 600lb	-- --
TMU-x025	-	--	DN25	600 [23,6]	DN40 DN50	600 [23,6] 600 [23,6]	¾" 150lb ¾" 600lb	600 [23,6] 600 [23,6]	1" 150lb 1" 600lb	650 [25,6] 675 [26,6]	1½" 150lb 1½" 600lb	650 [25,6] 675 [26,6]
TMU-x040	DN40	800 [31,5]	DN50	800 [31,5]	DN80 DN100	850 [33,5] 850 [33,5]	1½" 150lb 1½" 600lb	900 [35,4] 900 [35,4]	2" 150lb 2" 600lb	900 [35,4] 900 [35,4]	3" 150lb	900 [35,4]
TMU-x050	DN40 DN50	800 [31,5] 800 [31,5]	DN80 DN100	850 [33,5] 850 [33,5]	1½" 150lb 1½" 600lb	900 [35,4] 900 [35,4]	2" 150lb 2" 300lb	900 [35,4] 900 [35,4]	3" 150lb 3" 600lb	900 [35,4] 900 [35,4]	4" 150lb 4" 300lb	900 [35,4] 900 [35,4]
TMU-x080	DN50	1176 [46,3]	DN80	1196 [47,1]	DN100	1184 [46,6]	2" 150lb 2" 600lb	1207 [47,5] 1226 [48,3]	3" 150lb 3" 600lb	1218 [48,0] 1243 [48,9]	4" 150lb 4" 300lb	1230 [48,4] 1250 [49,2]
TMU-x100	DN80	1370 [53,9]	DN100	1358 [53,5]	DN150	1090 [42,9]	3" 150lb 3" 600lb	1388 [54,6] 1413 [55,6]	4" 150lb 4" 300lb	1400 [55,1] 1420 [55,9]	6" 150lb 6" 300lb	1154 [45,4] 1173 [46,2]
TMU-x150	DN100	1726 [68,0]	DN150	1732 [68,2]	DN200	1448 [57,0]	4" 150lb 4" 300lb	1770 [69,7] 1790 [70,5]	6" 150lb 6" 300lb	1796 [70,7] 1815 [71,5]	8" 150lb 8" 300lb	1525 [60,0] 1545 [60,8]
TMU-x200	DN150	2184 [86,0]	DN200	2198 [86,5]	DN300	1864 [73,4]	6" 150lb 6" 300lb	2250 [88,6] 2270 [89,4]	8" 150lb 8" 300lb	2270 [89,4] 2287 [90,0]	10" 150lb 10" 300lb	1925 [75,8] 1957 [77,0]
TMU-x250	DN200	2268 [89,3]	DN250	2284 [89,9]	DN300	1900 [74,8]	8" 150lb 8" 300lb	2348 [92,4] 2363 [93,0]	10" 150lb 10" 300lb	2348 [92,4] 2375 [93,5]	12" 150lb 12" 300lb	1945 [76,6] 1977 [77,8]
TMU-x300	DN250	2913 [114,7]	DN300	2925 [115,2]	DN350	2933 [115,5]	10" 150lb 10" 300lb	2976 [117,2] 3008 [118,4]	12" 150lb 12" 300lb	2995 [117,9] 3030 [119,3]	14" 150lb 14" 300lb	3020 [118,9] 3050 [120,1]

Other flanges on request

Table of Dimensions

Model	B					C	G
	Integrated mounted transmitter		Remote mount transmitter			mm [inch]	mm [inch]
	-40°C - 100°C (-40°F to 212°F)	-40°C - 150°C (-40°F to 302°F)	-40°C - 100°C (-40°F to 212°F)	-40°C - 180°C (-40°F to 356°F)	-40°C - 260°C (-40°F to 500°F)		
TMU-x008	354 [13,9]	456 [18,0]	223 [8,8]	325 [12,8]	425 [16,7]	82 [3,2]	35 [1,4]
TMU-x010	374 [14,7]	476 [18,7]	243 [9,6]	345 [13,6]	445 [17,5]	100 [3,9]	40 [1,6]
TMU-x012	444 [17,5]	546 [21,5]	313 [12,3]	415 [16,3]	515 [20,3]	160 [6,3]	60 [2,4]
TMU-x015	444 [17,5]	546 [21,5]	313 [12,3]	415 [16,3]	515 [20,3]	160 [6,3]	60 [2,4]
TMU-x020	505 [19,9]	607 [23,9]	374 [14,7]	476 [18,7]	576 [22,7]	211 [8,3]	80 [3,1]
TMU-x025	505 [19,9]	607 [23,9]	374 [14,7]	476 [18,7]	576 [22,7]	211 [8,3]	80 [3,1]
TMU-x040	664 [26,1]	766 [30,2]	533 [21,0]	635 [25,0]	735 [28,9]	312 [12,3]	136 [5,4]
TMU-x050	664 [26,1]	766 [30,2]	533 [21,0]	635 [25,0]	735 [28,9]	312 [12,3]	230 [9,1]
TMU-x080	1241 [48,9]	1343 [52,9]	1138 [44,8]	1240 [48,8]	1340 [52,8]	800 [31,5]	250 [9,8]
TMU-x100	1261 [49,6]	1363 [53,7]	1158 [45,6]	1260 [49,6]	1360 [53,5]	815 [32,1]	270 [10,6]
TMU-x150	1591 [62,6]	1693 [66,7]	1488 [58,6]	1590 [62,6]	1690 [66,5]	1070 [42,1]	380 [15,0]
TMU-x200	1751 [68,9]	1853 [73,0]	1648 [64,9]	1750 [68,9]	1850 [72,8]	1210 [47,6]	400 [15,7]
TMU-x250	1891 [74,4]	1993 [78,5]	1788 [70,4]	1890 [74,4]	1990 [78,3]	1300 [51,2]	550 [21,7]
TMU-x300	1896 [74,6]	1998 [78,7]	1793 [70,6]	1895 [74,6]	1995 [78,5]	1400 [55,1]	510 [20,1]

Heated Sensors

Sensors, equipped with heating plates, may have varying dimension depending on the mounted heating equipment and their associated flanges.